

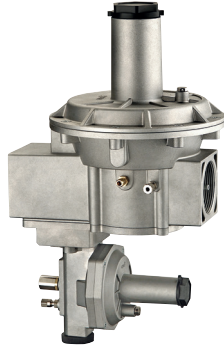

Gas Regulator

with Slam Shut Valve integrated
for Over (OPSO) and Under (UPSO) pressure - 500mbar/5bar
Mod. RG & RGD

English



MADE IN ITALY



GAS REGULATOR with SSV

RGD032-5B-SSV



- Gas Regulator with SSV:**
RG = Thread connections
RGD = Flanged connections
- DIMENSIONS:**
032 = 1" 1/4
040 = 1" 1/2
050 = 2"
D32 = DN32
D40 = DN40
D50 = DN50
- MAX PRESSURE:**
500 = 500mbar
5B = bar
- SSV:**
Slam Shut Valve

GENERAL DESCRIPTION

GAS REGULATOR SSV are single-stage gas regulators with pressure blocking device.

GAS REGULATOR SSV can be installed in systems with automatic gas burners and in industrial gas distribution systems.

GAS REGULATOR SSV have three diaphragms fitted inside them: a operating diaphragm (9), a compensation diaphragm (13) and a safety diaphragm (16) (refer to Fig. 3).

A breather pipe and external discharge is not necessary because the safety membrane avoids more than 30 dm³ / h, point 3.3.2 of the UNI-EN88-1: 2011 Norms.

The GAS REGULATOR SSV comply with the ATEX Directive 2014/34 / EU as device of group II, category 2G and as device of group II, category 2D; for this reason it is suitable for installation in zones 1 and 21 (as well as in zones 2 and 22) as classified in Annex I to Directive 99/92 / EC.

They are NOT suitable for installation in zones 0 and 20 as defined in the Directive 99/92 / EC.

We recommend checking the CEI EN 60079-10-1 standard to determine the qualification and extension of hazardous areas.

GAS REGULATOR SSV are equipped with:

- OVER PRESSURE blocking device (SSV) that blocks the pressure flow when the output pressure of the GAS REGULATOR SSV exceeds the set limit (OPSO).

- UNDER PRESSURE blocking device that blocks the pressure flow when the output pressure of the GAS REGULATOR SSV is lower than the set limit (UPSO).

WARNING: The GAS REGULATOR SSV will remain operated only if the pressure downstream is between the maximum value (OPSO) and the minimum value (UPSO) set.

MARKING

Depending on which model, GAS REGULATOR SSV are marked by laser with their technical characteristics. (Fig.1):

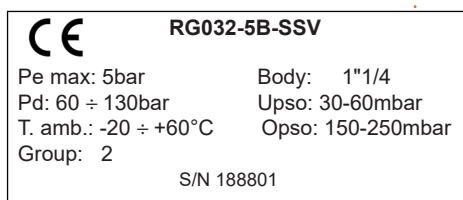

Fig.1

INSTALLATION AND POSITIONING

Any maintenance operation must be performed by qualified personnel.

This device must be installed in accordance with the laws in force.

The GAS REGULATOR SSV is normally installed before the user. It can be installed in a horizontal position and it must be installed with the arrow on the body towards the user. (Fig.2).

N.B. Install the GAS REGULATOR SSV away from atmospheric agents.

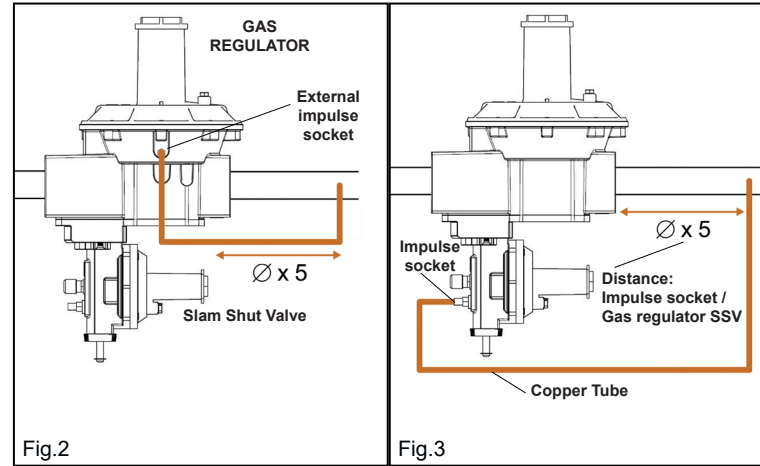

Fig.2

Fig.3

- Before proceeding with the installation, make sure that the gas supply has been shut-off.
- Check that the line pressure does NOT EXCEED the maximum pressure stated on the LABEL OF REGULATOR SSV.
- Make sure to respect the gas flow indicated by the arrow on the body of the GAS REGULATOR SSV which must always be directed towards the user.
- It is necessary to install an **impulse socket** for the shut-off valve with G 1/8 "connection and an **impulse socket** at the output of the GAS REGULATOR SSV at a distance of 5 times the nominal diameter of the pipe from the output of the same (Fig.3).

The two impulse sockets must be connected to each other with a copper tube with G 1/8 "connection.

GAS REGULATOR SSV if installed according all the indications of the following document it will not constitute a source of danger.

Only in particular fault conditions it will they be able to release flammable substances into the environment.

If the GAS REGULATOR SSV are installed in critical area (places not protected, lack of servicing, lacking availability of ventilation) and, especially in presence, close to the regulator, of potential sources of primer and/or dangerous devices during the normal working because susceptible to origine electric arcs or sparks, it is necessary to value before the compatibility between the regulator and these devices, we recommend removing the protective cap and connecting a tube with M10X1 connection. Place the other end of the tube outside the room. In this case the exhaust gas will be expelled into the external environment.

Make sure that debris or scraps have been created inside the network piping. Carefully check the connections made and check the tightness of the system.

GAS REGULATOR 500mbar/5 bar

RANGE SPRING (mbar)

Cod.	Color	Range (mbar)
500mbar - 5bar		
SPW2-5	WHITE	5 ÷ 14
SPY2-5	YELLOW	6 ÷ 22
SPN2-5	NEUTRAL	10 ÷ 27
SPR2-5	RED	28 ÷ 70
SPBK2-5	BLACK	60 ÷ 130
SPB2-5	BLUE	120 ÷ 300
SPBR2-5	BROWN	220 ÷ 480

SLAM SHUT VALVE

UPSO SPRING (mbar)

Cod.	Color	Range (mbar)
SPY2-U	YELLOW	10 ÷ 20
SPN2-U	NEUTRAL	30 ÷ 60

OPSO SPRING (mbar)

Cod.	Color	Range (mbar)
SPBK2-O	BLACK	150 ÷ 250
SPB2-O	BLUE	300 ÷ 500
SPBR2-O	BROWN	500 ÷ 700

DIRECTIVE 2012/19/UE (Waste from Electrical and Electronic Equipment - WEEE):

Information for users:

The label with the crossed-out wheeled bin symbol indicates that the product must not be disposed of with normal domestic waste. To avoid causing damage to the environment and human health, separate this product from other domestic waste so that it can be recycled in compliance with environmental protection procedures. For more details on available collection centers, please contact local government offices or the seller of the product.



ASSEMBLY OVERVIEW

- 1 Seal cap
- 2 O-Ring
- 3 Spring compressor
- 4 Washer
- 5 Screws
- 6 Vent cap
- 7 Upper cover
- 8 Plastic Washer
- 9 Safety diaphragm
- 10 Calibrated nozzle
- 11 Washer
- 12 Disc
- 13 Compensation diaphragm
- 14 Upper Bush
- 15 Disc
- 16 Working diaphragm
- 17 Lower bush
- 18 Cap
- 19 O-Ring
- 20 Body
- 21 Sensing Tube
- 22 Shaft
- 23 Seal washer
- 24 Shaft-Insert Assembly
- 25 Spring
- 26 Nut
- 27 Gasket
- 28 Cover
- 29 O-Ring
- 30 Release button
- 31 Spring
- 32 Fitting
- 33 O-Ring
- 34 Body
- 35 O-Ring
- 36 Reset knob
- 37 Seeger
- 38 O-Ring
- 39 Release shaft
- 40 Levers assembly
- 41 Spring
- 42 Shaft-membrane Assembly
- 43 O-Ring
- 44 Insert
- 45 Cap
- 46 Pressure outlet
- 47 Washer
- 48 Spring UPSO Min
- 49 Insert
- 50 Spring OPSO Max
- 51 Spring compressor UPSO
- 52 Spring compressor
- 53 O-Ring
- 54 Seal Cap
- 55 External impulse socket

Fig.4

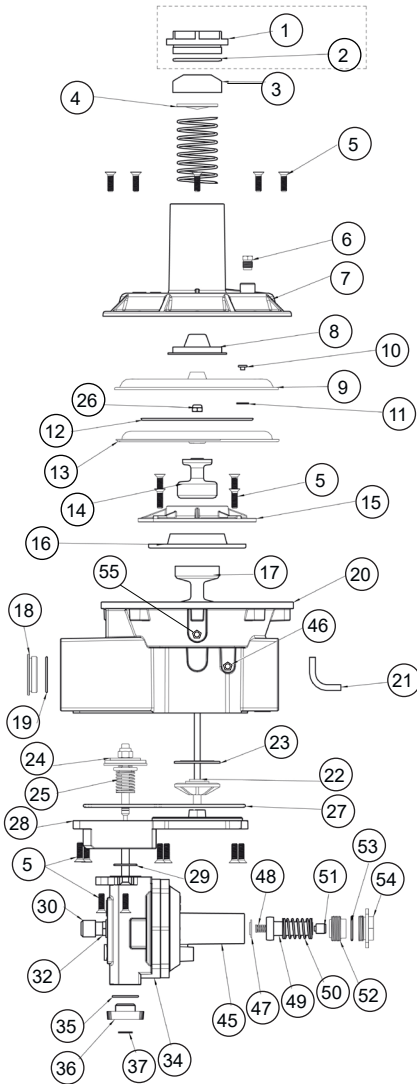

SETTING

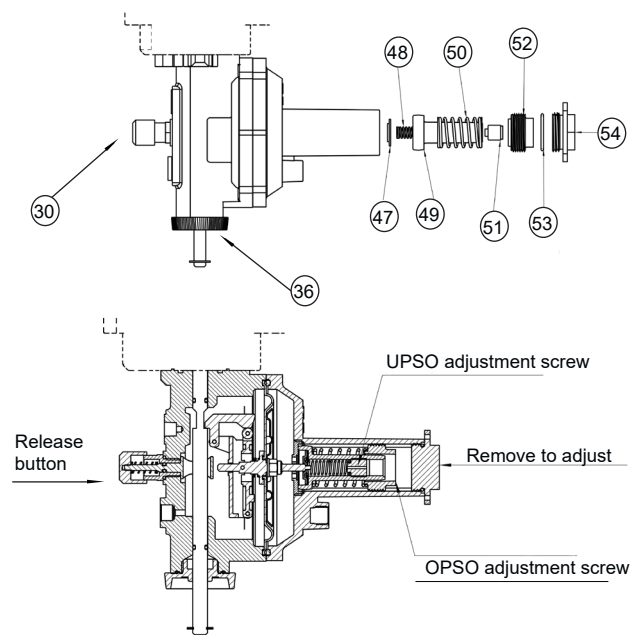

DIMENSIONS (mm) & WEIGHT (Kg)

mod. RG	A (mm)	B (mm)	C (mm)	D (mm)	WEIGHT (Kg)
1" 1/4	238	223	415	197	4,57
1" 1/2	238	223	415	197	4,52
2"	238	223	415	197	4,4

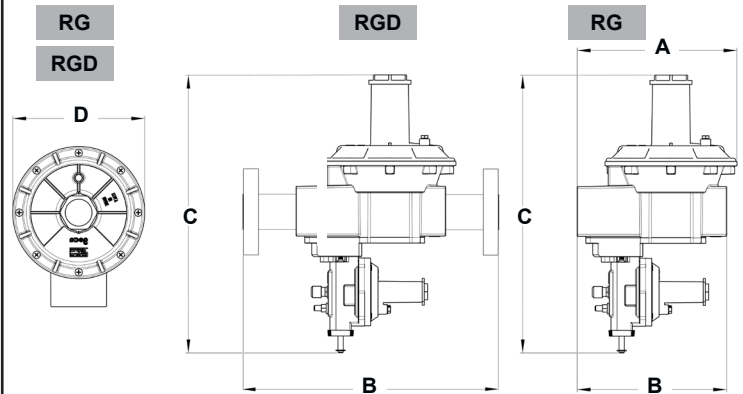

mod. RGD	A (mm)	B (mm)	C (mm)	D (mm)	WEIGHT (Kg)
DN32	/	325	415	197	6,06
DN40	/	335	415	197	6,25
DN50	/	320	415	197	6,41

GAS REGULATOR SSV

PRESSURE SETTING

Unscrew the **Seal cap** (1) to access to the **Spring compressor** (3) (Fig.4). The outlet pressure is regulated by rotating the **Spring compressor** (Fig.4). Using a 10mm Allen key, turn the **Spring compressor** (3) in a clockwise direction to increase the pressure and in an anticlockwise direction to reduce the pressure. After making the adjustment, replace the **Seal cap** (1).

MANUAL RESET

Make sure there is pressure inside the system and proceed as follows:

- Close the tap downstream of the GAS REGULATOR SSV.
- Unscrew and pull down the **Reset knob** (36).

For pressures over 2 bar, hold the Reset knob down until the pressure balance is created inside the system which allows the SSV to be reset (This may also occur after several seconds). If this is not the case, it means that the outlet pressure of the GAS REGULATOR SSV is lower than the minimum set pressure (UPSO).

RELEASE BUTTON

To stop the gas flow, firmly press the **RELEASE button** (30).

MAINTENANCE

GAS REGULATOR SSV do not require any specific maintenance. Yearly periodical inspection of regular working

If necessary, before carrying out any operation with the GAS REGULATOR SSV, make sure that gas supply has been shut off.

Any maintenance operation must be performed by qualified personnel.

TECHNICAL SPECIFICATIONS

Pmax: inlet max – 500 mbar or 5bar.
Setting outlet: available from 5 to 480mbar - choose the appropriate spring.

UPSO available from 10 to 60mbar - choose the appropriate spring.
OPSO available from 150 to 700mbar - choose the appropriate spring.
 Others configuration on request.

Inlet - Outlet Connection:

Thread gas 1"1/4, 1"1/2, 2"- ISO 228 connection
 DN32 DN40 DN50 - Sliding Aluminium flange PN10

Test point:

Inlet / outlet on request – Test point 1/8" NPT

Working Temperature:

- 20 °C ÷ + 60 °C

Use: Not aggressive gases of three families – Natural Gas – LPG –Town Gas

MATERIALS:

Complete Body: Die – Cast Aluminium Gd – AlSi12Cu – EN AB 46100

Diaphragms:

NBR 60Sh – DvGW EN 549

Plastic components: White POM / Pa 66 + 25% Gf



INSTRUCTION
LEAFLET

PAPER COLLECTION

Check the regulations
of your municipality



Tecnocontrol Srl
 Via Miglioli, n°47 20090 Segrate (MI)
 Italy Tel. +39 02 26922890
 www.tecnocontrol.it



GECA Srl
 Via E. Fermi, n°98 25064 Gussago (BS)
 Italy Tel. +39 030 3730218
 www.gecasrl.it

cpfgroup.it